

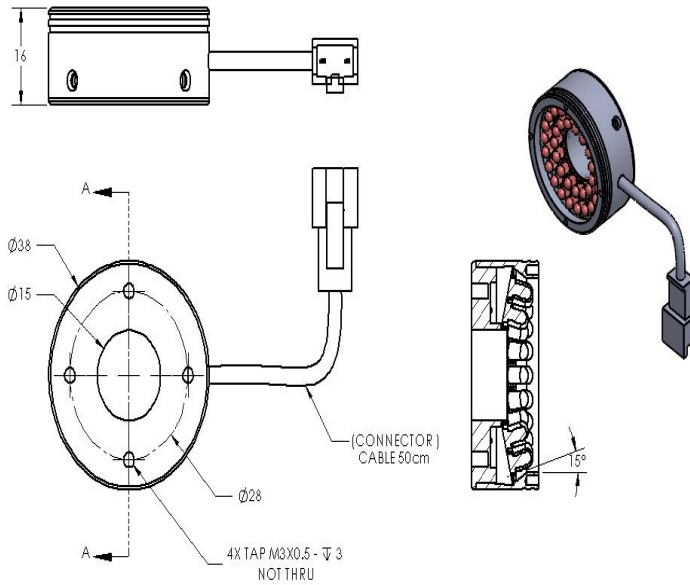

# PRE-ILLUMINATOR DATA (ID)

## LSW-15-038-2-G-24V

### Lighting Dimension



Mechanical Information	
Casing Material	Aluminium
Storage Temperature Range	Temp 0-45°C, Humidity 20-85%
Weight	32 g
Length / Outer Diameter	38 mm
Width / Inner Diameter	15 mm
Thickness / Height	10.3 mm



# PRE-ILLUMINATOR DATA (ID)

## LSW-15-038-2-G-24V

Optical Information			
Part Number	LSW-15-038-2-G-24V		
LED Color	GREEN		
Wavelength	(nm)	525	
Intensity (±15)	(Lux)	TBA	TBA
Working Distance	(mm)	8	47
Illumination (number of row)	2		
Illumination Active Area			
Active Length / Outer Dia.	(mm)	38	
Active Width / Inner Dia.	(mm)	15	
Emission angle	(deg.)	15	
Eye Safety Class ( IEC62471 )	EXEMPT		
Electrical Information			
Lighting Supply Voltage (constant voltage mode)	24V ± 2%		
Continuous Current	(mA)	90	
Power Consumption	(W)	2.16	
Lighting casing temperature, Operating after 60 minutes	°C	TBA	
Strobe Mode Specification			
Pulse Operation	YES		
Max. Lighting Supply Voltage (Constant voltage power supply)	(V)	Pulsing at 24VDC to 48VDC, 0-10% Duty Cycle Recommended at 36VDC	
Pulse Current, (Max. 10msec) (Constant current power supply)	(mA)	270	
Max. Trigger Pulse Duration	(msec)	10	
Duty Cycle	0-10%		
Additional Information			
Additional Cooling Method	Attached to machine part for better heat dissipation		
Intensity Controller Selection	ANG, SD, SDA and ST series		
CE Conformity	YES		
RoHS Compliance	YES		
Connection			
Connector Type (Default):	JST SMR-03V		
Cable Length out from lighting :	(mm)	500	
Pin Configuration :	Pin	Signal	Cable Color
	1	LED +	RED
	2	N.C.	---
	3	LED -	WHITE
			
Application			
Illumination Type	Direct Illumination		
Application Use	substrate inspection, label inspection, flat surface, fiducially recognition		



**VISION CONSULTANCY**  
MAKING THE UNSEEN VISIBLE

Thank you for downloading this document from  
[www.machine-vision-shop.com](http://www.machine-vision-shop.com)

If you have any questions, you need help composing the  
right package for your application or do you want to order?

Feel free to contact us via e-mail at [sales@vision-consultancy.nl](mailto:sales@vision-consultancy.nl) or visit our webshop.

Our vision experts are happy to help you.



Natascha Overhof



Christian Cromptvoets



**VISION CONSULTANCY**

Robert Schumandomein 2  
6229 ES Maastricht  
The Netherlands

+31 (0) 438 522 651

[sales@vision-consultancy.nl](mailto:sales@vision-consultancy.nl)  
[www.machine-vision-shop.com](http://www.machine-vision-shop.com)

Scan me to visit  
[machine-vision-shop](http://machine-vision-shop.com)

