

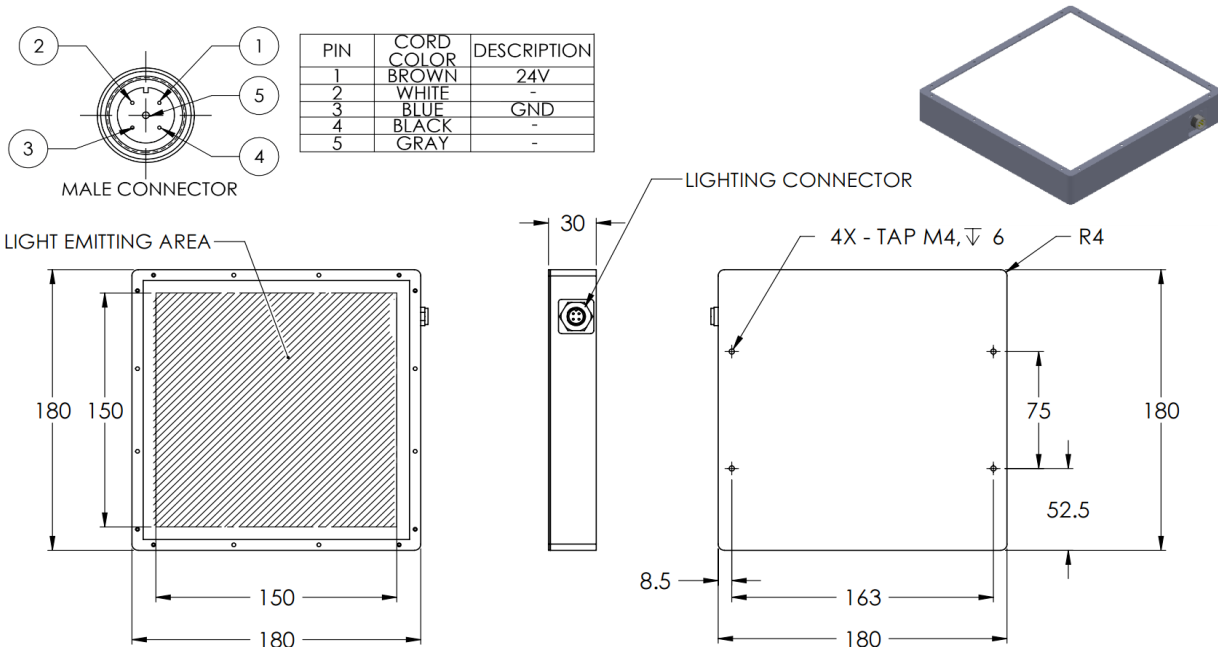

ILLUMINATOR DATA-ID

BHP1515-X-G-24V

Lighting Dimension



| Mechanical Information | |
|---------------------------|--------------------------------|
| Casing Material | Aluminium |
| Storage Temperature Range | Temp 0 - 45°C, Humidity 20-85% |
| Weight | 1000 g |
| Length / Outer Diameter | 180 mm |
| Width / Inner Diameter | 180 mm |
| Thickness / Height | 30 mm |



ILLUMINATOR DATA-ID

BHP1515-X-G-24V

| Optical Information | | | | |
|---|--------|---|--------|--------------|
| Part Number | | BHP1515-X-G-24V | | |
| LED Color | | GREEN | | |
| Wavelength | (nm) | 525 | | |
| Intensity (±15%) | (Lux) | 35600 | 32600 | 30100 |
| Working Distance | (mm) | 10 | 20 | 30 |
| Illumination (number of row) | | X | | |
| Illumination Active Area | | | | |
| Active Length / Outer Diameter | (mm) | 150 | | |
| Active Width / Inner Diameter | (mm) | 150 | | |
| Emission angle | (deg.) | 0 | | |
| Eye Safety Class (IEC62471) | | EXEMPT | | |
| Electrical Information | | | | |
| Lighting Supply Voltage (constant voltage mode) | | 24V ± 2% | | |
| Continuous Current | (mA) | 840 | | |
| Power Consumption | (W) | 20.16 | | |
| Lighting casing temperature, Operating after 60 minutes | °C | 44.2 | | |
| Strobe Mode Specification | | | | |
| Pulse Operation | | YES | | |
| Max. Lighting Supply Voltage (Constant voltage power supply) | (V) | Pulsing at 24VDC to 48VDC, 0-10% Duty Cycle, Recommended at 36VDC | | |
| Pulse Current, (Max. 10msec) (Constant current power supply) | (mA) | 2520 | | |
| Max. Trigger Pulse Duration | (msec) | 10 | | |
| Duty Cycle | | 0-10% | | |
| Additional Information | | | | |
| Additional Cooling Method | | Attached to machine part for better heat dissipation | | |
| Intensity Controller Selection | | ANG, ST, SD and SDA Series | | |
| CE Conformity | | YES | | |
| RoHS Compliance | | YES | | |
| Connection | | | | |
| Connector Type (default) | | M12 5 PIN CONNECTOR (MALE) | | |
| Cable Length (out from lighting) | (mm) | 700 | | |
| Pin Configuration | | Pin | Signal | Cable Colour |
| | | 1 | 24V | BROWN |
| | | 2 | - | WHITE |
| | | 3 | GND | BLUE |
| | | 4 | - | BLACK |
| | | 5 | - | GRAY |
| | | | | |
| Extension Cable | | | | |
| Connector Type (default) | | M12 5 PIN CONNECTOR (FEMALE) | | |
| Part Number | | EXT-FL-M12F-3M-24V | | |
| Cable Length (out from female connector) | (mm) | 3000 | | |
| Extension Cable (connect to M12 5 Pin Male Connector from lighting) | | | | |
| Application | | | | |
| Illumination Type | | Ingress Protection Illumination | | |
| Applicattion Use | | Lead frame inspection, shape recognition, size measurement. | | |



VISION CONSULTANCY
MAKING THE UNSEEN VISIBLE

Thank you for downloading this document from
www.machine-vision-shop.com

If you have any questions, you need help composing the
right package for your application or do you want to order?

Feel free to contact us via e-mail at sales@vision-consultancy.nl or visit our webshop.

Our vision experts are happy to help you.



Natascha Overhof



Christian Cromptoets



VISION CONSULTANCY

Robert Schumandomein 2
6229 ES Maastricht
The Netherlands

+31 (0) 438 522 651

sales@vision-consultancy.nl
www.machine-vision-shop.com

Scan me to visit
[machine-vision-shop](http://machine-vision-shop.com)

